

Dynamic correction to moment approximations

Iliya V. Karlin* and Alexander N. Gorban
Computing Center RAS, Krasnoyarsk, 660036, Russian Federation

G. Dukek and T. F. Nonnenmacher
Department of Mathematical Physics, University of Ulm, D-89069 Ulm, Germany
 (Received 13 January 1997)

Considering the Grad moment ansatz as a suitable first approximation to a closed finite-moment dynamics, the correction is derived from the Boltzmann equation. The correction consists of two parts, local and nonlocal. Locally corrected thirteen-moment equations are demonstrated to contain exact transport coefficients. Equations resulting from the nonlocal correction give a microscopic justification to some phenomenological theories of extended hydrodynamics. [S1063-651X(98)03502-8]

PACS number(s): 05.60.+w, 44.10.+i, 47.10.+g, 51.10.+y

A considerable part of the modern development of non-equilibrium thermodynamics is based on the idea of extension of the list of relevant variables. Various phenomenological and semiphenomenological theories in this domain are known under the common title of extended irreversible thermodynamics (EIT) [1]. With this, the question of a microscopic justification of the EIT becomes important. Recall that a justification for some of the versions of the EIT was found within the well-known Grad moment method [2].

Originally, the Grad moment approximation was introduced for the purpose of solving the Boltzmann-like equations of the classical kinetic theory. The Grad method is used in various kinetic problems, e.g., in plasma and in phonon transport. We mention also that Grad equations assist in understanding asymptotic features of gradient expansions, both in linear and in nonlinear domains [3].

The essence of the Grad method is to introduce an approximation to the one-particle distribution function f , which would depend only on a finite number N of moments, and, subsequently, to use this approximation to derive a closed system of N moment equations from the kinetic equation. The number N (the level at which the moment transport hierarchy is truncated) is not specified in the Grad method. One particular way to choose N is to obtain an estimation of the transport coefficients (viscosity and heat conductivity) sufficiently close to their exact values provided by the Chapman-Enskog method (CE) [4]. In particular, for the thirteen-moment (13M) Grad approximation it is well known that transport coefficients are equal to the first Sonine polynomial approximation to the exact CE values. Accounting for higher moments with $N > 13$ can improve this approximation (good for neutral gases but poor for plasmas [5]). However, what should be done, starting with the 13M approximation, to come to the exact CE transport coefficients is an open question. It is also well known [6] that the Grad method provides a poorly converging approximation when applied to strongly nonequilibrium problems (such as shock and kinetic layers).

Another question comes from the approximate character of the Grad equations, and is discussed in frames of the EIT: while the Grad equations are strictly hyperbolic at any level N (i.e., predicting a finite speed of propagation), will this feature will be preserved in the further corrections?

These two questions are special cases of a more general one, namely, how does one derive a closed description with a given number of moments? Such a description is sometimes called mesoscopic [7] since it occupies an intermediate level between the hydrodynamic (macroscopic) and the kinetic (microscopic) levels of description.

In this paper we aim at deriving the mesoscopic dynamics of thirteen moments in the simplest case when the kinetic description satisfies the linearized Boltzmann equation. Our approach will be based on the two assumptions: (i) The mesoscopic dynamics of thirteen moments exists, and is invariant with respect to the microscopic dynamics. (ii) The 13M Grad approximation is a suitable first approximation to this mesoscopic dynamics. The assumption (i) is realized as the invariance equation for the (unknown) mesoscopic distribution function. Following the assumption (ii), we solve the invariance equation iteratively, taking the 13M Grad approximation for the input approximation, and consider the first iteration (further we refer to this as to the dynamic correction, to distinguish from constructing another ansatz). We demonstrate that the correction results in the exact CE transport coefficients. We also demonstrate how the dynamic correction modifies the hyperbolicity of the Grad equations. A similar viewpoint on derivation of hydrodynamics was earlier developed in [8] (we will return to a comparison below).

First, we review the Boltzmann equation and the 13M Grad approximation. We denote as n_0 , $\mathbf{u}_0 = 0$, and p_0 the equilibrium values of the hydrodynamic parameters (n is the number density, \mathbf{u} is the average velocity, and $p = nk_B T$ is the pressure). The global Maxwell distribution function F is

$$F = n_0 (v_T)^{-3} \pi^{-3/2} \exp(-c^2),$$

where $v_T = \sqrt{2k_B T_0 m^{-1}}$ is the equilibrium heat velocity, and $\mathbf{c} = \mathbf{v} - \mathbf{v}_T$ is the peculiar velocity of a particle. The near-equilibrium dynamics of the distribution function, $f = F(1 + \varphi)$, is due to the linearized Boltzmann equation:

*Author to whom correspondence should be addressed. Present address: Istituto Applicazioni Calcolo, CNR, Via del Policlinico, 137 00161 Roma, Italy.

$$\begin{aligned}\partial_t \varphi &= \hat{J} \varphi \equiv -v_T \mathbf{c} \cdot \nabla \varphi + \hat{L} \varphi, \\ \hat{L} \varphi &= \int w F(\mathbf{v}_1) [\varphi(\mathbf{v}'_1) + \varphi(\mathbf{v}') \\ &\quad - \varphi(\mathbf{v}_1) - \varphi(\mathbf{v})] d\mathbf{v}'_1 d\mathbf{v}' d\mathbf{v}_1,\end{aligned}$$

where \hat{L} is the linearized collision operator, and w is the probability density of pair encounters.

$n = \delta n/n_0$, $\mathbf{u} = \delta \mathbf{u}/v_T$, $p = \delta p/p_0$ ($p = n + T$, $T = \delta T/T_0$) are dimensionless deviations of the hydrodynamic variables, while $\boldsymbol{\sigma} = \delta \boldsymbol{\sigma}/p_0$ and $\mathbf{q} = \delta \mathbf{q}/(p_0 v_T)$ are dimensionless deviations of the stress tensor $\boldsymbol{\sigma}$, and of the heat flux \mathbf{q} . The linearized 13M Grad distribution function is $f_0 = F(\mathbf{c})[1 + \varphi_0]$, where

$$\begin{aligned}\varphi_0 &= \varphi_1 + \varphi_2, \quad \varphi_1 = n + 2\mathbf{u} \cdot \mathbf{c} + T[c^2 - (3/2)], \\ \varphi_2 &= \overline{\boldsymbol{\sigma} \cdot \mathbf{c} \mathbf{c}} + (4/5)\mathbf{q} \cdot \mathbf{c}[c^2 - (5/2)].\end{aligned}\quad (1)$$

The overbar denotes a symmetric traceless dyad.

The 13M Grad's equations are derived in two steps: first, the 13M Grad's distribution function (1) is inserted into the linearized Boltzmann equation to give a formal expression, $\partial_t \varphi_0 = \hat{J} \varphi_0$, second, projector P_0 is applied to this expression, where $P_0 = P_1 + P_2$:

$$\begin{aligned}P_1 &= \frac{F_0}{n_0} \left\{ X_0 \int X_0 \cdot d\mathbf{v} + \mathbf{X} \cdot \int \mathbf{X} \cdot d\mathbf{v} + X_4 \int X_4 \cdot d\mathbf{v} \right\}, \\ P_2 &= \frac{F_0}{n_0} \left\{ \mathbf{Y} \cdot \int \mathbf{Y} \cdot d\mathbf{v} + \mathbf{Z} \cdot \int \mathbf{Z} \cdot d\mathbf{v} \right\}.\end{aligned}\quad (2)$$

Here $X_0 = 1$, $\mathbf{X} = \sqrt{2}\mathbf{c}$, $X_4 = \sqrt{2/3}(c^2 - \frac{3}{2})$, $\mathbf{Y} = \sqrt{2}\overline{\mathbf{c} \mathbf{c}}$, and $\mathbf{Z} = (2/\sqrt{5})\mathbf{c}(c^2 - \frac{5}{2})$. The resulting equation,

$$P_0[F \partial_t \varphi_0] = P_0[F \hat{J} \varphi_0],$$

is a compressed representation for the 13M Grad equations for the macroscopic variables $M_{13} = \{n, \mathbf{u}, T, \boldsymbol{\sigma}, \mathbf{q}\}$.

Now we turn to the main purpose of this paper, and derive the dynamic correction to the 13M distribution function (1). The assumption (i) (existence of closed dynamics of thirteen moments) implies the invariance equation for the true mesoscopic distribution function, $\tilde{f}(M_{13}, \mathbf{c}) = F[1 + \tilde{\varphi}(M_{13}, \mathbf{c})]$, where we have stressed that this function depends parametrically on the same thirteen macroscopic parameters, as the original Grad approximation. The invariance condition for $\tilde{f}(M_{13}, \mathbf{c})$ reads [8]

$$(1 - \tilde{P})[F \hat{J} \tilde{\varphi}] = 0, \quad (3)$$

where \tilde{P} is the projector associated with \tilde{f} . Generally speaking, the projector \tilde{P} depends on the distribution function \tilde{f} [8,9]. In the following, we use the projector P_0 (2), which will be consistent with our approximate treatment of Eq. (3).

Following the assumption (ii) [13M Grad's distribution function (1) is a good initial approximation], the Grad's function f_0 and the projector P_0 are chosen as the input data

for solving Eq. (3) iteratively. The dynamic correction amounts to the first iterate. Let us consider these steps in more detail.

Substituting φ_0 (1) and P_0 (2) instead of φ and P in Eq. (3), we get $(1 - P_0)[F \hat{J} \varphi_0] \equiv \Delta_0 \neq 0$, which demonstrates that (1) is not a solution of Eq. (3). Moreover, Δ_0 splits in two natural pieces: $\Delta_0 = \Delta_0^{\text{loc}} + \Delta_0^{\text{nloc}}$, where

$$\Delta_0^{\text{loc}} = (1 - P_2)[F \hat{L} \varphi_2], \quad \Delta_0^{\text{nloc}} = (1 - P_0)[-v_T F \mathbf{c} \cdot \nabla \varphi_0]. \quad (4)$$

Here we have accounted for $P_1[F \hat{L} \varphi] = 0$, and $\hat{L} \varphi_1 = 0$. The first piece of Eq. (4), Δ_0^{loc} , can be termed *local* because it does not account for spatial gradients. Its origin is twofold. In the first place, recall that we are performing our analysis in a non-local-equilibrium state (the 13M approximation is not a zero point of the Boltzmann collision integral, hence $\hat{L} \varphi_0 \neq 0$). In the second place, specializing to the linearized case under consideration, functions $\overline{\mathbf{c} \mathbf{c}}$ and $\mathbf{c}[c^2 - (5/2)]$, in general, are not the eigenfunctions of the linearized collision integral, and hence $P_2[F \hat{L} \varphi_0] \neq F \hat{L} \varphi_0$, resulting in $\Delta_0^{\text{loc}} \neq 0$ [10].

Using Cartesian coordinates and summation convention, the nonlocal part may be written as

$$\Delta_0^{\text{nloc}} = -v_T f_0 (\Pi_1 |_{krs} \partial_k \sigma_{rs} + \Pi_2 |_{ik} \overline{\partial_k q_i} + \Pi_3 \partial_k q_k), \quad (5)$$

where $\partial_i = \partial/\partial x_i$, and Π are velocity polynomials:

$$\begin{aligned}\Pi_1 |_{krs} &= c_k [c_r c_s - (1/3) \delta_{rs} c^2] - (2/5) \delta_{ks} c_r c^2, \\ \Pi_2 |_{ik} &= (4/5) [c^2 - (7/2)] [c_i c_k - (1/3) \delta_{ik} c^2], \\ \Pi_3 &= (4/5) [c^2 - (5/2)] [c^2 - (3/2)] - c^2.\end{aligned}$$

We seek the dynamic correction of the form

$$f = f_0 [1 + \varphi_0 + \phi].$$

Substituting $\varphi = \varphi_0 + \phi$, and $P = P_0$, into Eq. (3), we derive an equation for the correction ϕ :

$$(1 - P_2)[F \hat{L}(\varphi_2 + \phi)] = (1 - P_0)[v_T F \mathbf{c} \cdot \nabla(\varphi_0 + \phi)]. \quad (6)$$

Equation (6) should be supplied with the additional condition, $P_0[F \phi] = 0$.

Let us apply the usual ordering to solve the Eq. (6), introducing a small parameter ϵ , multiplying the collision integral \hat{L} with ϵ^{-1} , and expanding $\phi = \sum_n \epsilon^n \phi^{(n)}$. Subject to the additional condition, the resulting sequence of linear integral equations is uniquely soluble. Let us consider the first two orders in ϵ .

Because $\Delta_0^{\text{loc}} \neq 0$, the leading correction is of the order ϵ^0 , i.e., of the same order as the initial approximation φ_0 . The function $\phi^{(0)}$ is due to the following equation:

$$(1 - P_2)[F \hat{L}(\varphi_2 + \phi^{(0)})] = 0, \quad (7)$$

subject to the condition $P_0[F \phi^{(0)}] = 0$. Equation (7) has the unique solution $\varphi_2 + \phi^{(0)} = \boldsymbol{\sigma} \cdot \mathbf{Y}^{(0)} + \mathbf{q} \cdot \mathbf{Z}^{(0)}$, where functions $\mathbf{Y}^{(0)}$ and $\mathbf{Z}^{(0)}$ are solutions of the integral equations:

$$\hat{L}Y^{(0)} = bY, \quad \hat{L}Z^{(0)} = aZ, \quad (8)$$

subject to the conditions $P_1[f_0 Y^{(0)}] = 0$ and $P_1[f_0 Z^{(0)}] = 0$. Factors a and b are

$$a = \pi^{-3/2} \int e^{-c^2} Z^{(0)} \cdot \hat{L}Z^{(0)} d\mathbf{c},$$

$$b = \pi^{-3/2} \int e^{-c^2} Y^{(0)} \cdot \hat{L}Y^{(0)} d\mathbf{c}.$$

Now we are able to notice Eq. (8) coincides with the CE equations [4] for the *exact transport coefficients* (viscosity and temperature conductivity). Emergence of these well known equations in the present context is important and rather unexpected: *when the moment transport equations are closed with the locally corrected function $f^{\text{loc}} = F(1 + \varphi_0 + \phi^{(0)})$, we come to a closed set of thirteen equations containing the exact CE transport coefficients.*

Let us analyze the next order (ϵ^1), where Δ_0^{nlloc} comes into play. To simplify matters, we neglect the difference between the exact and the approximate CE transport coefficients. The correction $\phi^{(1)}$ is due to the equation

$$(1 - P_2)[F\hat{L}\phi^{(1)}] + \Delta_0^{\text{nlloc}} = 0, \quad (9)$$

the additional condition is $P_0[f_0\phi^{(1)}] = 0$. The problem (9) reduces to three integral equations of a familiar form:

$$\hat{L}F_{1|krs} = \Pi_{1|krs}, \quad \hat{L}F_{2|ik} = \Pi_{2|ik}, \quad \hat{L}F_3 = \Pi_3, \quad (10)$$

subject to the following conditions: $P_1[F_0 F_{1|krs}] = 0$, $P_1[F_0 F_{2|ik}] = 0$, and $P_1[F_0 F_3] = 0$. Integral equations (10) are of the same structure as are the integral equations appearing in the CE method, and the methods to handle them are well developed [4]. In particular, a reasonable and simple approximation is to take $F_{i|\dots} = -A_i \Pi_{i|\dots}$. Then

$$\phi^{(1)} = -v_T (A_1 \Pi_{1|krs} \partial_k \sigma_{rs} + A_2 \Pi_{2|ik} \partial_k q_i + A_3 \Pi_3 \partial_k q_k), \quad (11)$$

where A_i are the approximate values of the kinetic coefficients, and which are expressed via matrix elements of the linearized collision integral:

$$A_i^{-1} \alpha - \int \exp(-c^2) \Pi_{i|\dots} \hat{L} \Pi_{i|\dots} d\mathbf{c} > 0. \quad (12)$$

The estimation can be extended to a computational scheme for any given molecular model (e.g., for the Lennard-Jones potential), in the manner of the transport coefficients computations in the CE method.

To summarize the results of the dynamic correction, we quote first the unclosed equations for the variables $M_{13} = M_{13} = \{n, \mathbf{u}, T, \boldsymbol{\sigma}, \mathbf{q}\}$:

$$(1/v_T) \partial_t n + \nabla \cdot \mathbf{u} = 0, \quad (13a)$$

$$(2/v_T) \partial_t \mathbf{u} + \nabla(T + n) + \nabla \cdot \boldsymbol{\sigma} = 0, \quad (13b)$$

$$(1/v_T) \partial_t T + (2/3) \nabla \cdot \mathbf{u} + (2/3) \nabla \cdot \mathbf{q} = 0, \quad (13c)$$

$$(1/v_T) \partial_t \boldsymbol{\sigma} + 2 \overline{\nabla \mathbf{u}} - (2/3) \nabla \mathbf{q} + \nabla \cdot \mathbf{h} = \mathbf{R}, \quad (13d)$$

$$(2/v_T) \partial_t \mathbf{q} - (5/2) \nabla p - (5/2) \nabla \cdot \boldsymbol{\sigma} + \nabla \cdot \mathbf{g} = \mathbf{R}. \quad (13e)$$

Terms spoiling the closure are the higher moments of the distribution function,

$$\mathbf{h} = 2 \pi^{-3/2} \int e^{-c^2} \boldsymbol{\varphi} \mathbf{c} \mathbf{c} \mathbf{c} d\mathbf{c}, \quad \mathbf{g} = 2 \pi^{-3/2} \int e^{-c^2} \boldsymbol{\varphi} \mathbf{c} \mathbf{c} c^2 d\mathbf{c},$$

and the ‘‘moments’’ of the collision integral,

$$\mathbf{R} = \frac{2}{v_T} \pi^{-3/2} \int e^{-c^2} \mathbf{c} \mathbf{c} \hat{L} \boldsymbol{\varphi} d\mathbf{c},$$

$$\mathbf{R} = \frac{2}{v_T} \pi^{-3/2} \int e^{-c^2} \mathbf{c} c^2 \hat{L} \boldsymbol{\varphi} d\mathbf{c}.$$

The 13M Grad’s distribution function (1) provides the closing approximation to both the higher moments and the ‘‘moments’’ of the collision integral:

$$\mathbf{R}_0 = -\mu_0^{-1} \boldsymbol{\sigma}, \quad \mathbf{R}_0 = -\lambda_0^{-1} \mathbf{q},$$

$$\nabla \cdot \mathbf{h}_0 = (2/3) 1 \nabla \cdot \mathbf{q} + (4/5) \overline{\nabla \mathbf{q}},$$

$$\nabla \cdot \mathbf{g}_0 = (5/2) \nabla(p + T) + (7/2) \nabla \cdot \boldsymbol{\sigma}, \quad (14)$$

where μ_0 and λ_0 are the first Sonine polynomial approximations to the viscosity and the temperature conductivity coefficients [4], respectively.

The local correction improves the closure of the ‘‘moments’’ of collision integral:

$$\mathbf{R} = -\mu_{\text{CE}}^{-1} \boldsymbol{\sigma}, \quad \mathbf{R} = -\lambda_{\text{CE}}^{-1} \mathbf{q}, \quad (15)$$

where index CE corresponds to exact Chapman-Enskog values of the transport coefficients.

The nonlocal correction adds the following terms to the higher moments:

$$\nabla \cdot \mathbf{g} = \nabla \cdot \mathbf{g}_0 - A_3 \nabla \nabla \cdot \mathbf{q} - A_2 \nabla \cdot \overline{\nabla \mathbf{q}},$$

$$\nabla \cdot \mathbf{h} = \nabla \cdot \mathbf{h}_0 - A_1 \nabla \cdot \nabla \boldsymbol{\sigma}, \quad (16)$$

where A_i are the kinetic coefficients derived above.

In order to illustrate what changes in Grad equations with the nonlocal correction, let us consider a model with two scalar variables, $T(x, t)$ and $q(x, t)$ (a simplified case of the one-dimensional corrected 13M system where one retains only the variables responsible for heat conduction):

$$\partial_t T + \partial_x q = 0, \quad \partial_t q + \partial_x T - a \partial_x^2 q + q = 0. \quad (17)$$

Parameter $a \geq 0$ controls ‘‘turning on’’ the nonlocal correction. Using $\{f(k, \omega), T(k, \omega)\} \exp(\omega t + i k x)$, we come to a dispersion relation for the two roots $\omega_{1,2}(k)$. Without the correction ($a = 0$), there are two domains of k : for $0 \leq k < k_-$, dispersion is diffusionlike [$\text{Re} \omega_{1,2}(k) \leq 0$, $\text{Im} \omega_{1,2}(k) = 0$], while as $k \geq k_-$, dispersion is wavelike [$\omega_1(k) = \omega_2^*(k)$, $\text{Im} \omega_1(k) \neq 0$]. For a between 0 and 1, the dispersion modifies in the following way: the wavelike domain becomes bounded, and exists for $k \in]k_-(a), k_+(a)[$, while

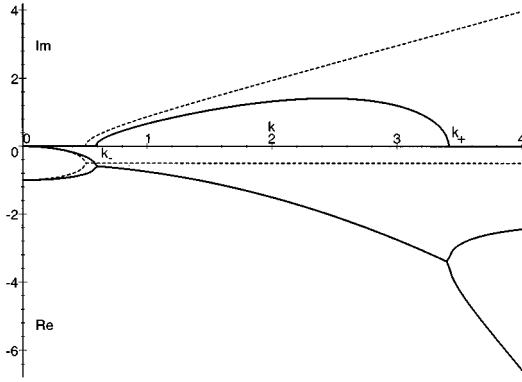

FIG. 1. Attenuation $\text{Re}\omega_{1,2}(k)$ (lower pair of curves), frequency $\text{Im}\omega_{1,2}(k)$ (upper pair of curves). Dashed lines: Grad case ($a=0$), solid lines: dynamic correction ($a=0.5$).

the diffusionlike domain consists of two pieces, $k < k_-(a)$ and $k > k_+(a)$. The dispersion relation for $a=1/2$ is shown in the Fig. 1. As a increases to 1, the boundaries of the wave-like domain, $k_-(a)$ and $k_+(a)$, move towards each other, and collapse at $a=1$. For $a > 1$, the dispersion relation becomes purely diffusive ($\text{Im}\omega_{1,2}=0$) for all k .

We close this paper with a discussion.

(i) Considering the 13M Grad ansatz as a suitable approximation to the closed dynamics of thirteen moments, we have found that the first correction leads to exact Chapman-Enskog transport coefficients. Further, the nonlocal part of this correction extends the Grad equations with terms containing spatial gradients of the heat flux and of the stress tensor, destroying the hyperbolic nature of the former. Corresponding kinetic coefficients are explicitly derived for the Boltzmann equation.

(ii) Extension of Grad equations with terms like those in Eq. (16) was mentioned in many versions of the EIT [11]. These derivations were based on phenomenological and semi-phenomenological arguments, in particular, the extension of the heat flux with appealing to nonlocality effects in dense fluids. Here we have derived the similar contribution from the *simplest* (i.e., dilute gas) kinetics, in fact, from the assumption about the existence of the mesoscopic dynamics. The advantage of using the simplest kinetics is that corresponding kinetic coefficients (12) become a matter of a *computation* for any molecular model. This computational aspect will be discussed elsewhere, since it affects the dilute gas contribution to dense fluids fits. Here we would like to stress a formal support of the relevance of the above analysis: the

nonlocal piece of dynamic correction is intermediated by the local correction, *improving* the 13M Grad estimation to the ordinary transport coefficients.

(iii) When the invariance principle is applied to derive hydrodynamics (closed equations for the variables n , \mathbf{u} and T) then [8] the local Maxwellian f_{lm} is chosen as the input distribution function for the invariance equation. In the linear domain, $f_{lm}=F[1+\varphi_1]$, and the projector is $P_{lm}=P_1$; see Eqs. (1) and (2). When the latter expressions are substituted into the invariance equation (3), we obtain $\Delta_{lm}=\Delta_{lm}^{\text{nlc}}=-v_T F\{2\nabla\mathbf{u}\cdot\mathbf{c}\mathbf{c}+\nabla T\cdot\mathbf{c}[c^2-(5/2)]\}$, while $\Delta_{lm}^{\text{loc}}\equiv 0$ because the local Maxwellians are zero points of the Boltzmann collision integral. Consequently, the dynamic correction begins with the order ϵ , and the analog of Eq. (9) reads

$$\hat{L}\phi_{lm}^{(1)}=v_T\{2\nabla\mathbf{u}\cdot\mathbf{c}\mathbf{c}+\nabla T\cdot\mathbf{c}[c^2-(5/2)]\},$$

subject to the condition $P_1[F\phi_{lm}^{(1)}]=0$. The latter is the familiar Chapman-Enskog equation, resulting in the Navier-Stokes correction to the Euler equations [4]. Thus, *the nonlocal dynamic correction is related to the 13M Grad equations entirely in the same way as the Navier-Stokes are related to the Euler equations*. As the final comment to this point, it was recently demonstrated with simple examples [3] that the invariance principle, as applied to the derivation of hydrodynamics, is equivalent to the summation of the Chapman-Enskog expansion.

(iv). Let us discuss briefly the further corrections. The first local correction [the functions Y_1 and Z_1 in Eq. (8)] is not the limiting point of our iterational procedure. When the latter is continued, the subsequent local corrections are found from integral equations, $\hat{L}Y_{n+1}=b_{n+1}Y_n$, and $\hat{L}Z_{n+1}=a_{n+1}Z_n$. Thus, we are led to the following two eigenvalue problems: $\hat{L}Y_\infty=b_\infty Y_\infty$, and $\hat{L}Z_\infty=a_\infty Z_\infty$, where, in accord with general argument [8], a_∞ and b_∞ are the closest to zero eigenvalues among all the eigenvalue problems with the given tensorial structure [12].

(v) The approach of this paper can be extended to derive dynamic corrections to other (nonmoment) approximations of interest in the kinetic theory. The above analysis has demonstrated, in particular, the importance of the local correction, generically relevant to an approximation that is not a zero point of the collision integral.

I.V.K. acknowledges the support of the Alexander von Humboldt Foundation, the Italian Ministry of Research (CNR), and the support of the RFBR through Grant No. 95-02-03836-a (A.N.G. and I.V.K.).

- [1] D. Jou, J. Casas-Vázquez, and G. Lebon, *Extended Irreversible Thermodynamics*, 2nd ed. (Springer, Berlin, 1996); I. Müller and T. Ruggeri, *Extended Thermodynamics* (Springer, Berlin, 1993), and references therein.
 [2] H. Grad, *Commun. Pure Appl. Math.* **2**, 331 (1949).
 [3] A. N. Gorban and I. V. Karlin, *Phys. Rev. Lett.* **77**, 282 (1996); I. V. Karlin, G. Dukek, and T. F. Nonnenmacher, *Phys. Rev. B* **55**, 6324 (1997); *Phys. Rev. E* **55**, 1573 (1997).

- [4] S. Chapman and T. Cowling, *Mathematical Theory of Non-uniform Gases* (Cambridge University Press, Cambridge, 1970).
 [5] R. Balescu, *Transport Processes in Plasmas* (North-Holland, Amsterdam, 1988), Vol. 1.
 [6] M. E. Widder and U. M. Titulaer, *J. Stat. Phys.* **56**, 471 (1989); *Physica A* **167**, 663 (1990).
 [7] T. Dedeurwaerde *et al.*, *Phys. Rev. E* **53**, 498 (1996).

- [8] A. N. Gorban and I. V. Karlin, *Transp. Theory Stat. Phys.* **23**, 559 (1994).
- [9] Dependence of projectors on the distribution functions was discussed extensively in the paper: R. Balian, Y. Alhassid, and H. Reinhardt, *Phys. Rep.* **131**, 1 (1986).
- [10] Except for Maxwellian molecules (interaction potential $U \sim r^{-4}$) for which $\hat{L}\varphi_0 \neq 0$ but $P_2[F\hat{L}\varphi_G] = F\hat{L}\varphi_0$. Same goes for the relaxation time approximation of the collision integral ($\hat{L} = -\tau^{-1}$).
- [11] R. F. Rodríguez *et al.*, *Phys. Lett.* **107A**, 17 (1985); R. E. Nettleton, *J. Math. Phys.* **36**, 1825 (1995); G. Lebon and M. Grmela, *Phys. Lett. A* **214**, 184 (1996); M. Grmela, *Phys. Rev. E* **47**, 351 (1993).
- [12] In a recent paper, A. N. Gorban and I. V. Karlin, *Phys. Rev. E* **54**, R3109 (1996), alternative Grad-like approximations were suggested, and which use the ‘‘moments’’ of collision integral instead of the moments of the distribution function. When this approximation is taken as the input for the corrections procedure instead of the Grad’s as above, the local corrections satisfy the following integral equations: $\hat{L}Y_n = \bar{b}_n Y_{n+1}$, and $\hat{L}Z_n = \bar{a}_n Z_{n+1}$. Thus, both the inputs have the same limiting eigenvalue problems but proceed to this limit via apparently different sequences of approximations.